

READ AND FOLLOW ALL SAFETY INSTRUCTIONS!

- Before installing, servicing, or performing routine maintenance, follow these general precautions.
- Electrical Wiring Installation should be performed by a qualified licensed electrician.
- Maintenance of the luminaires should be performed by person(s) familiar with the luminaires' construction and operation and any hazards involved.
- It will occasionally be necessary to clean the outside of the refractor/lens. Frequency of cleaning will depend on ambient dirt level and minimum light output which is acceptable to user. Lens should be washed with a damp cloth of warm water and any mild, non-abrasive household detergent, wiped with clean water and wiped dry.
- Recycle: For information on how to recycle LED electronic products, please visit www.epa.gov.
- These instructions may not cover all details, risks or install variations in connection with installation, operation, or maintenance. Should further information be desired, or should particular problems arise which are not covered sufficiently for the purchaser's or owner's purposes, these matters should be referred to BrightWave.

READ AND FOLLOW ALL SAFETY INSTRUCTIONS!

1. Before installing this fixture or doing any maintenance, make sure to turn off the power supply at the circuit breaker or fuse box.
2. Do not handle energized module with wet hands or when standing on wet or damp surfaces, or in water.
3. Check to make sure that all the fixture connections have been properly made and the fixture is grounded to avoid potential electrical shocks.
4. Product must be installed in accordance with NEC or your local electrical code. If you are not familiar with these codes and requirements, consult a qualified electrician.

WARNING - Risk of Electric Shock. Maximum connected load with a single power supply shall not exceed maximum ampacity rating of #18 AWG through-wire conductors. Avoid handling LEDs directly. Not intended for use in environments containing airborne corrosive agents such as chemical solvents, cleaners, or cutting fluids

DELIVERY: Upon receipt of fixture and accessories, inspect for any freight damage. All damage should be reported to the delivery carrier. Compare the catalog description listed on the packing slip with the fixture label to be sure you have received the correct merchandise.

ELECTRICIAN INSTRUCTIONS

1. Follow specific building lighting plans for installation location of each item.
2. 15 amp circuits are required for BrightWave.
3. Lights will handle 120v - 277v circuits. Any questions please contact a BrightWave representative.
4. All wire runs and AWGs need to follow electrical code.

PARTS AND HARDWARE PROVIDED:

Z-Bracket Assembly

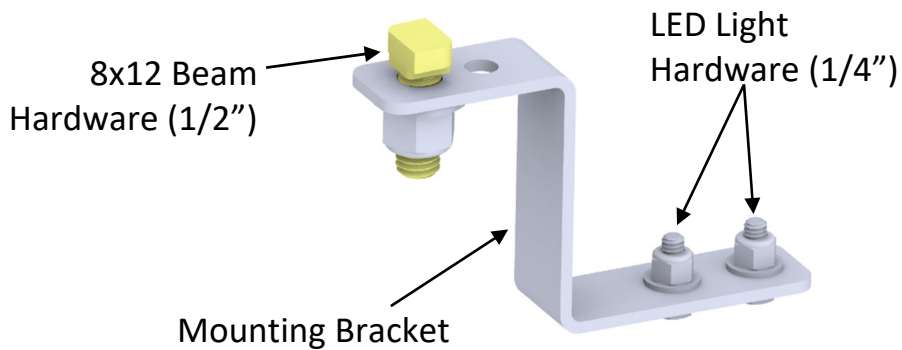

J-Box Assembly

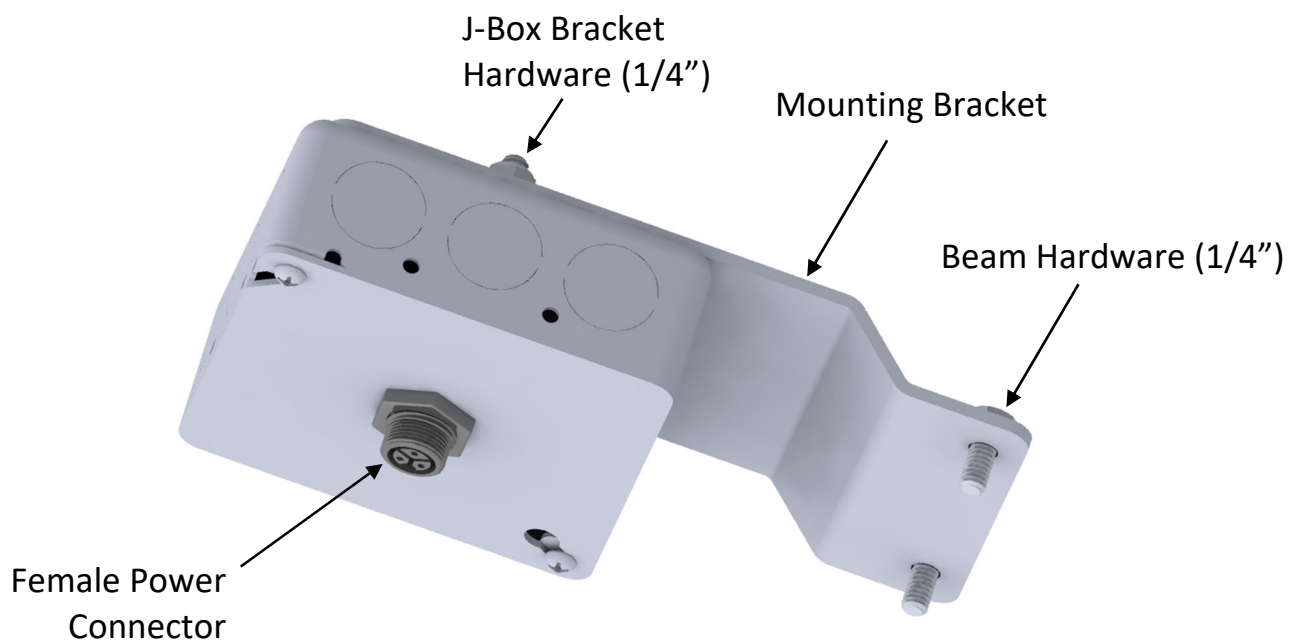

Power Cable



LED Lights

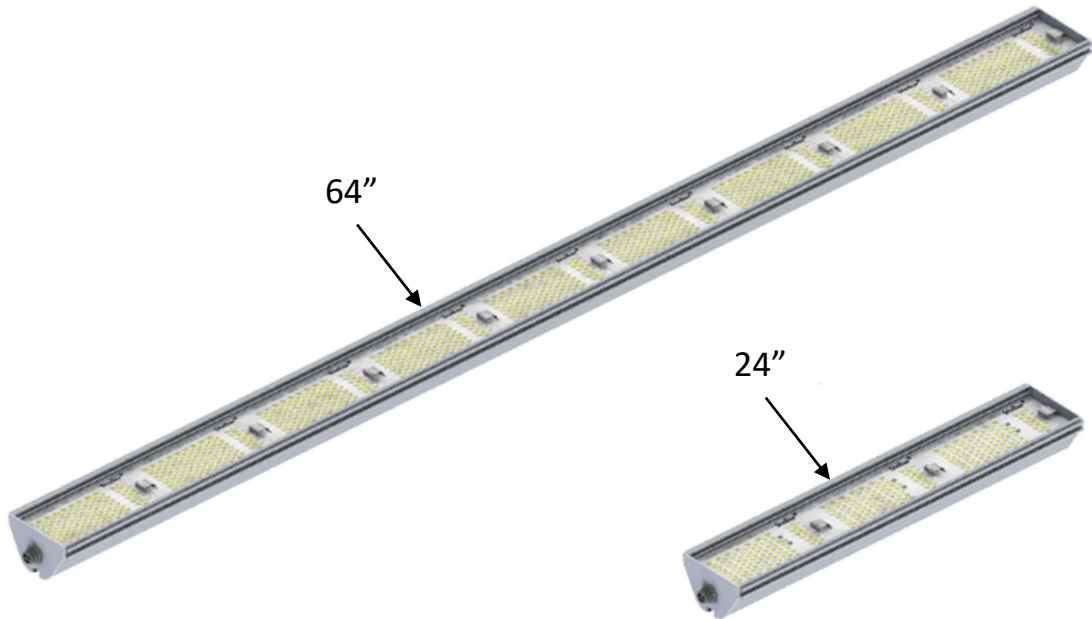

J-BOX & LED LIGHT INSTALLATION

160 x 170 Arch Layout

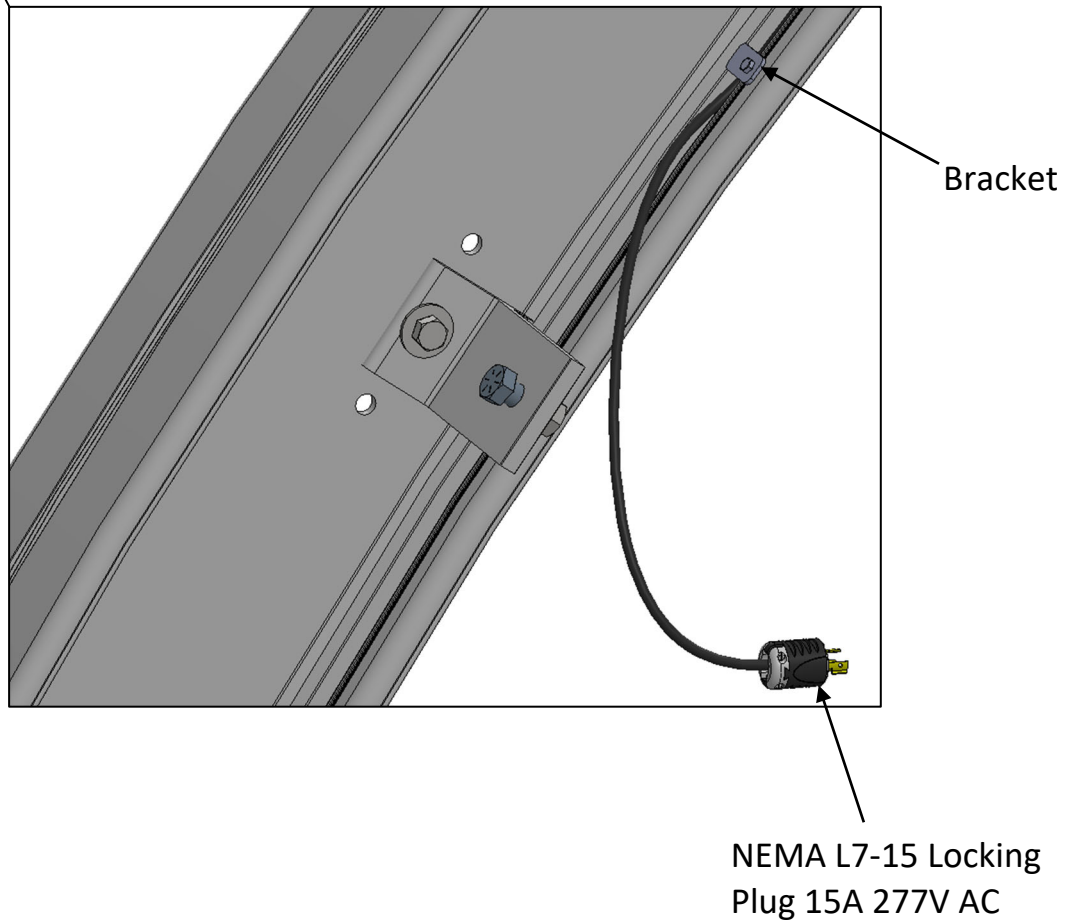
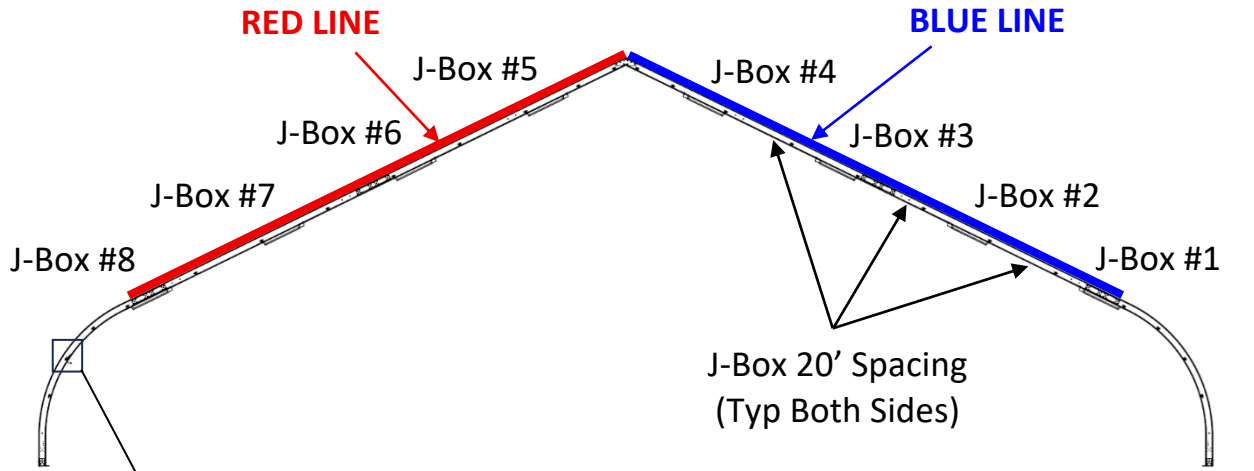

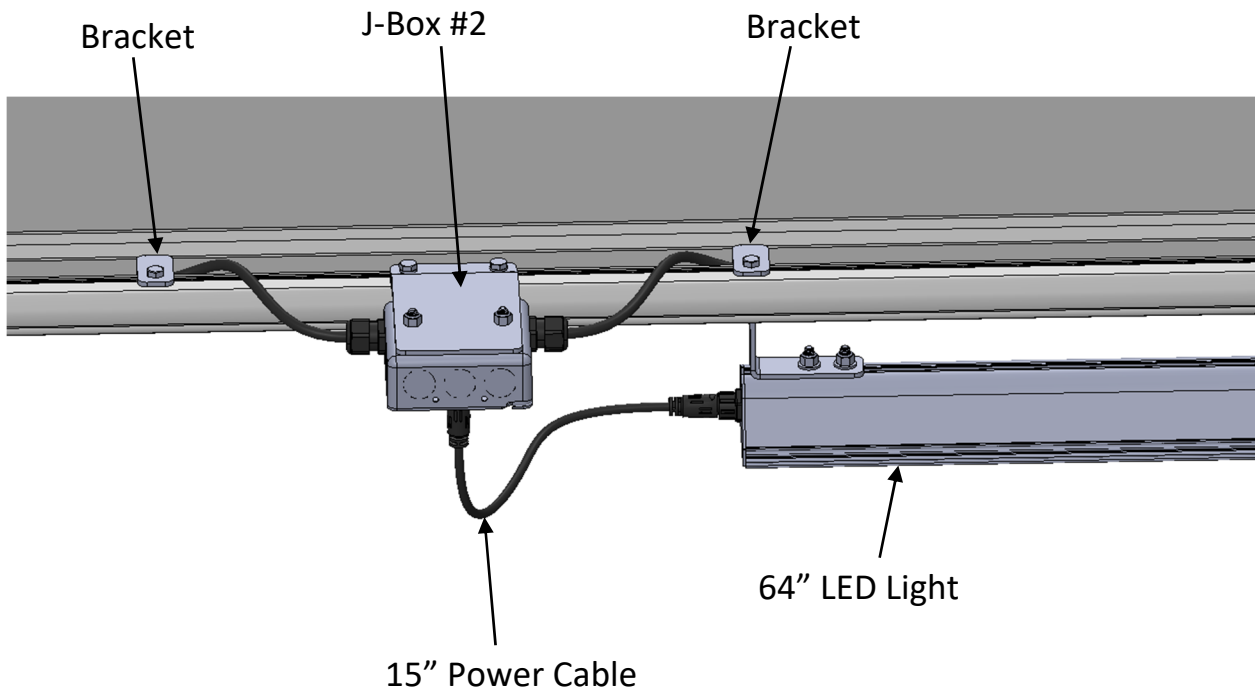
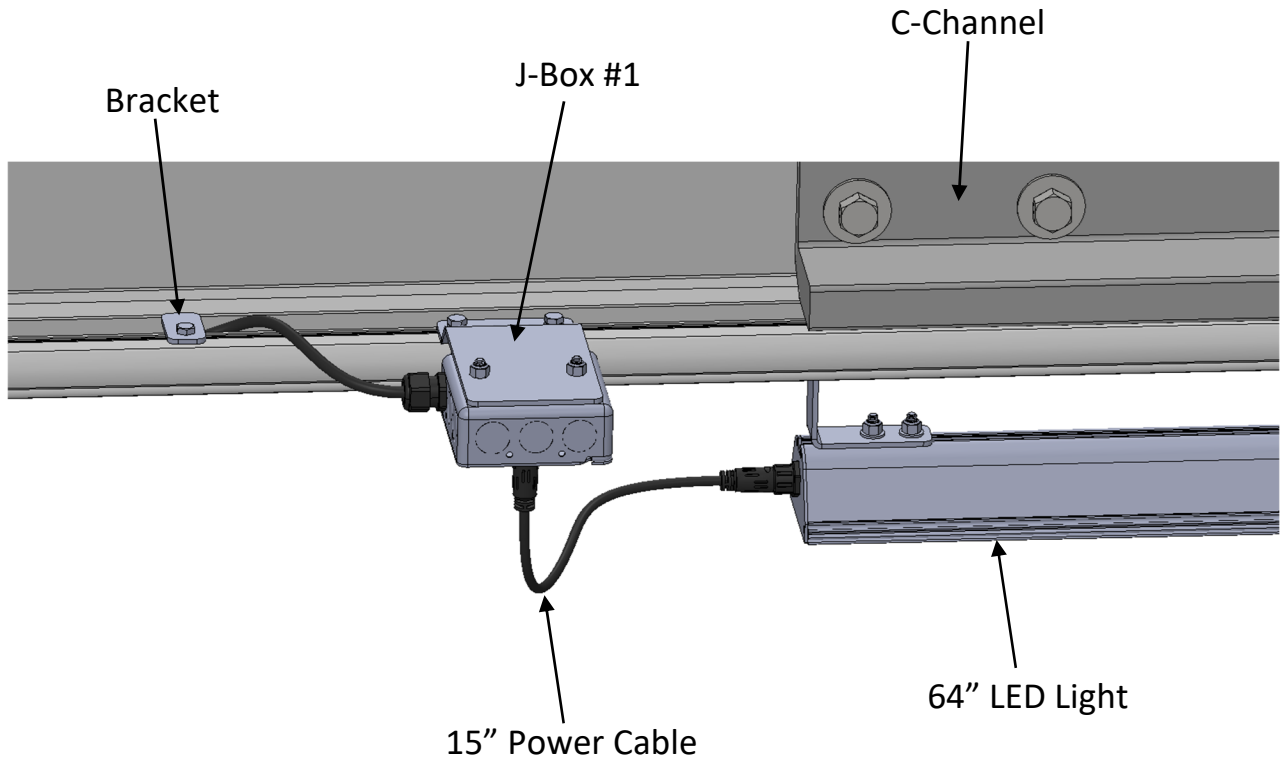

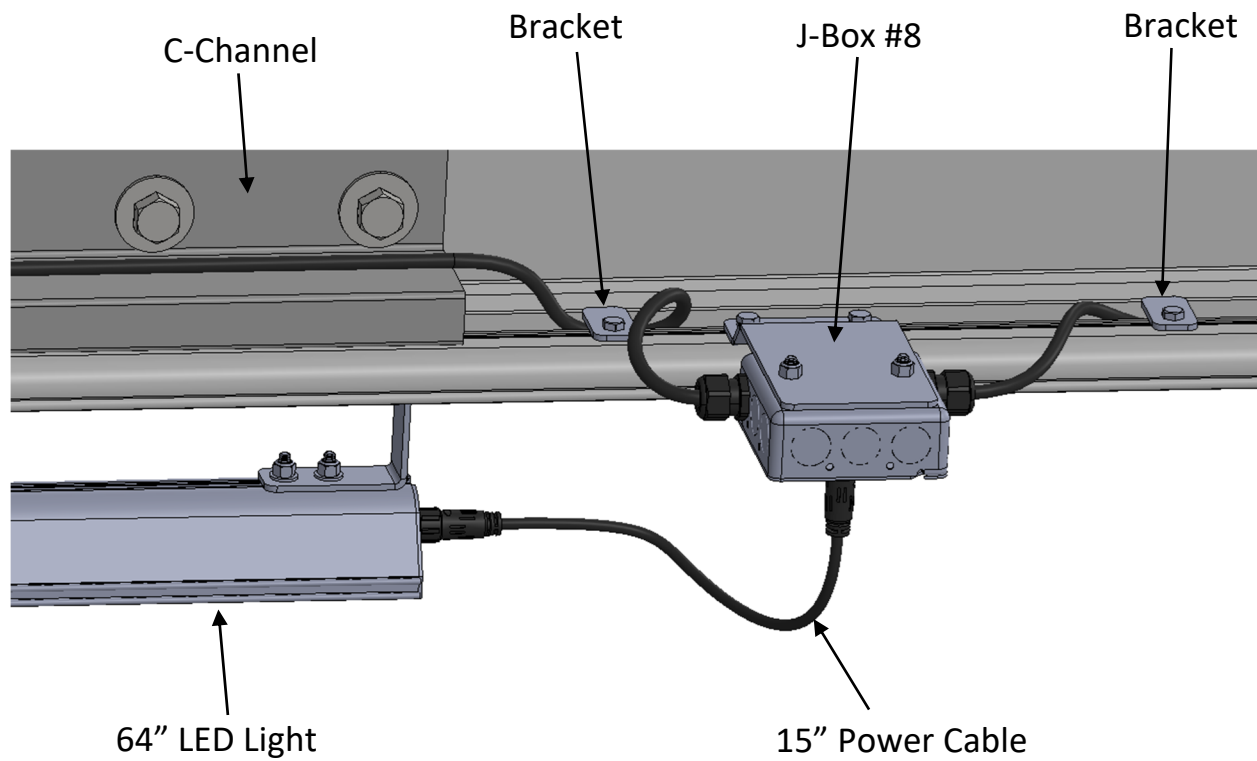
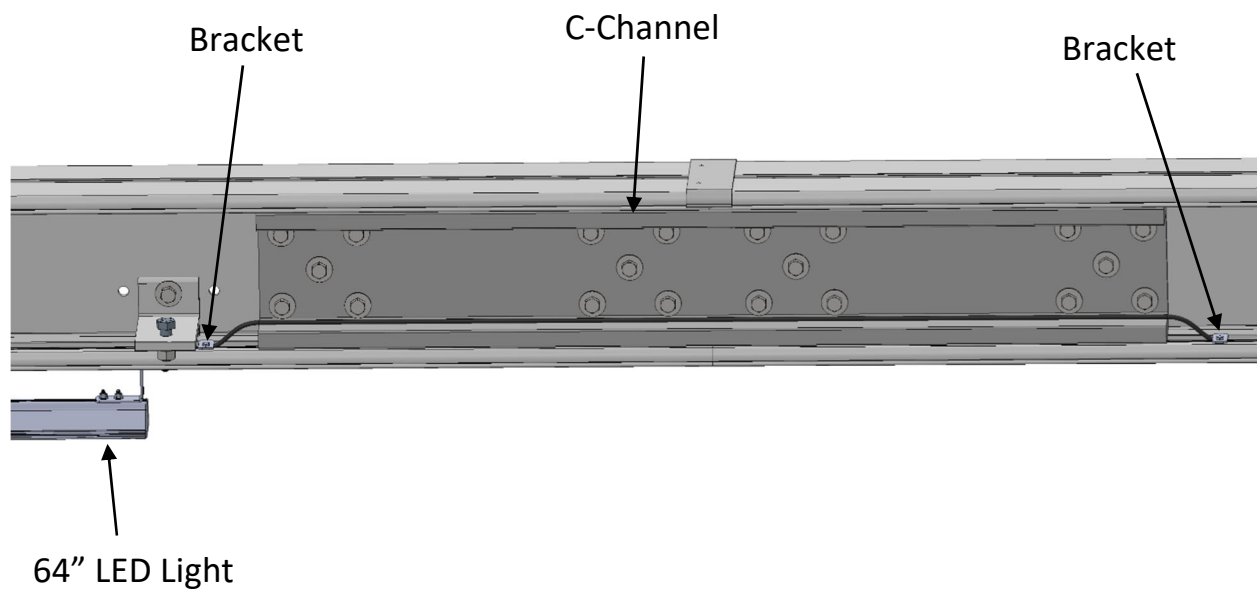

NOTE: Refer to the following drawings for specific hardware callouts and assembly instructions:

- AIRCRAFT HANGER (160 X 170)
- 64" LIGHT MOUNT ASSEMBLY - 8X12 BEAM
- J-BOX ASSEMBLY

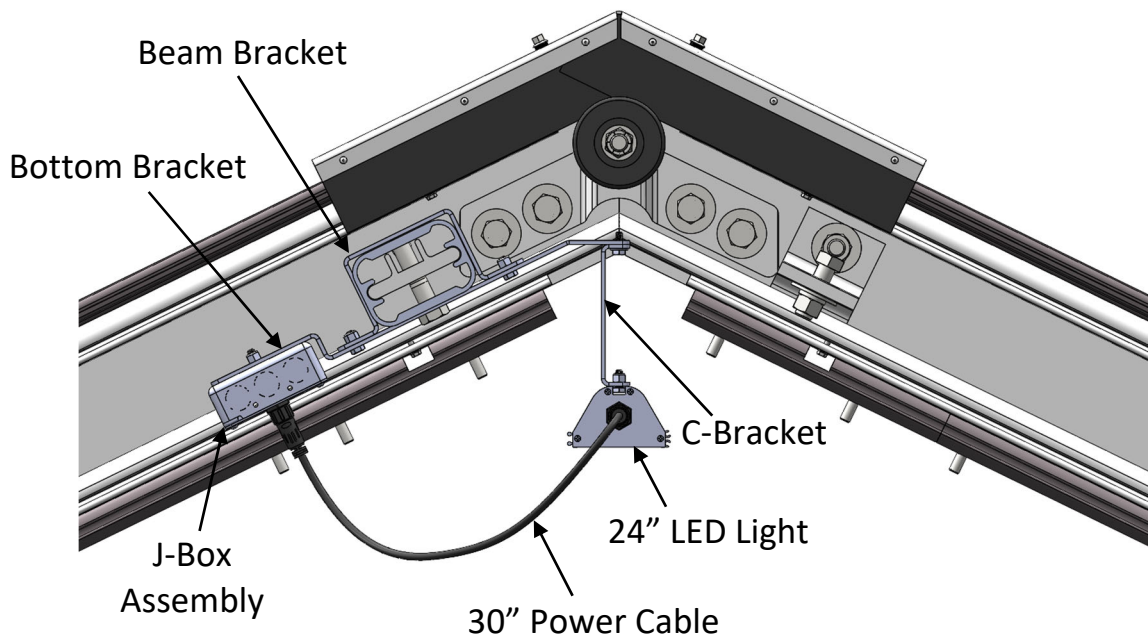
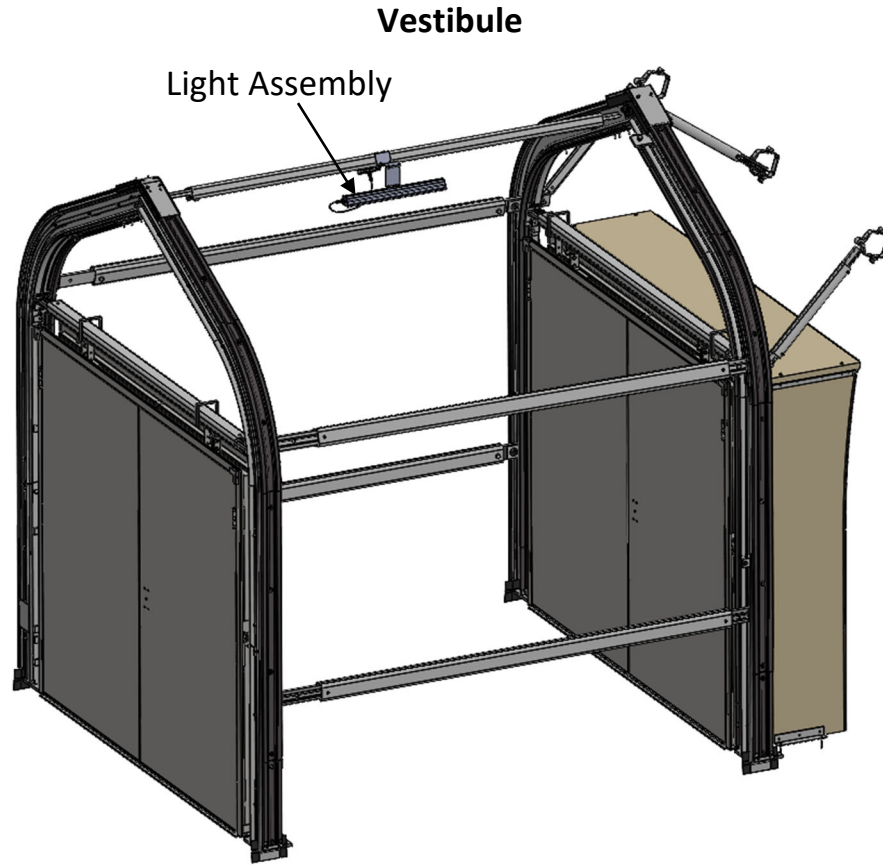

NOTE: Refer to **VESTIBULE LIGHT ASSEMBLY - NO LINER** drawing for specific hardware callouts and assembly instructions

